

## Energi Savr Node DALI® Universal

The Energi Savr Node unit is a DALI-2® certified DIN-rail mounted single master application controller for use with DALI®-compliant digital addressable loads in Athena, Quantum, and myRoom plus systems. It provides DALI® bus power and control for two independent DALI® buses with up to 64 DALI®-compliant, digital addressable loads on each bus.

### Model Numbers

QSN-2DALUNV-D

QSN-2DALUNV-S

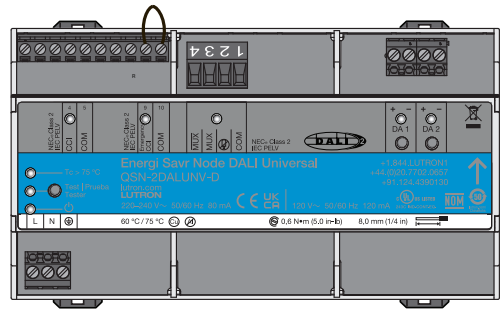

QSN-2DALUNV-D



QSN-2DALUNV-S

Feature	Athena	Quantum <sup>1</sup>	myRoom plus <sup>1</sup>
DALI® single master application controller	✓	✓	✓
# of supported DALI® compliant buses	2	2	2
# of supported DALI® compliant loads per bus	64	64	64
# of Lutron zones per bus	64	64	64
Supports DALI® IEC62386-102 standard fade times	✓	✓	✓
Fade time support of up to 4 hours	✓	X	X
Supports DALI® IEC62386-202 (Type 1) self-contained emergency loads	✓	✓	X
Supports DALI® IEC62386-209 (Type 8) tunable white (t <sub>c</sub> ) loads	✓	X	X
Supports dual channel white tunable loads	X <sup>2</sup>	✓	X
Supports perceived intensity control	✓	✓	✓
Simultaneous control of color <sup>3</sup> and intensity with independent fade times	✓	X	X
Dynamic DALI® group allocation <sup>4</sup>	✓	X	X
Field configurable system failure level, minimum/maximum levels, and fade times	✓	✓	✓
Power failure memory retains control unit programming in the event of power loss	✓	✓	✓
Lights remain unchanged during firmware upgrade	✓	✓	✓

<sup>1</sup> Available in Quantum version 3.4.441 or greater, myRoom plus version 3.3.441 or greater. Quantum systems lower than 3.3.441 will require a billable upgrade to the latest version of Quantum. Contact your local Lutron Representative for more information.

<sup>2</sup> Dual channel white tunable load support has been replaced with Type 8 tunable white loads for Athena system.

<sup>3</sup> Actual color temperature output is determined by the tolerance of the third-party driver.

<sup>4</sup> Dynamic DALI® group allocation automatically and intelligently assigns zones to DALI® groups to maximize dimming performance and minimize asynchronous behavior of loads within a zone.

### DALI® Compatibility

The Lutron Energi Savr Node DALI® Universal (ESN) is DALI-2® certified by the Digital Illumination Interface Alliance® (DiiA®). In order to ensure compatibility with Lutron DALI® controllers, the connected DALI® LED drivers and fluorescent ballasts must be DALI-2® certified and marked. In addition to compatibility, it is important to select high-quality and high-performance LED drivers and fluorescent ballasts. DALI-2® certified devices are readily available from many manufacturers and are tested for compatibility with the standard. For a complete list of available DALI-2® certified devices, see the DiiA® website at <https://www.digitalilluminationinterface.org/products>. DALI® devices that are not listed on the DiiA® website and are not marked DALI-2® cannot be considered DALI-2® certified.

The DALI® version-1 standard does not ensure compatibility. To apply the original DALI® version-1 mark on LED drivers and fluorescent ballasts, no verification of the test results was required, and manufacturers could self-declare compliance and apply the DALI® mark. If you would like to use an LED driver or fluorescent ballast that is not DALI-2® certified but carries a DALI® version-1 logo, Lutron recommends that these devices be tested to ensure compatibility. Lutron is able to perform this testing on request. Samples of the drivers and light engines must be submitted to Lutron and the expected turnaround time is 6 to 8 weeks after the drivers are received. Fees for testing may apply. Lutron recommends that this testing be performed before the fixtures and lighting controls are purchased and installed. Contact your Lutron sales representative for more information.

<b>Job Name:</b>	<b>Model Numbers:</b>
<b>Job Number:</b>	

# Typical Application

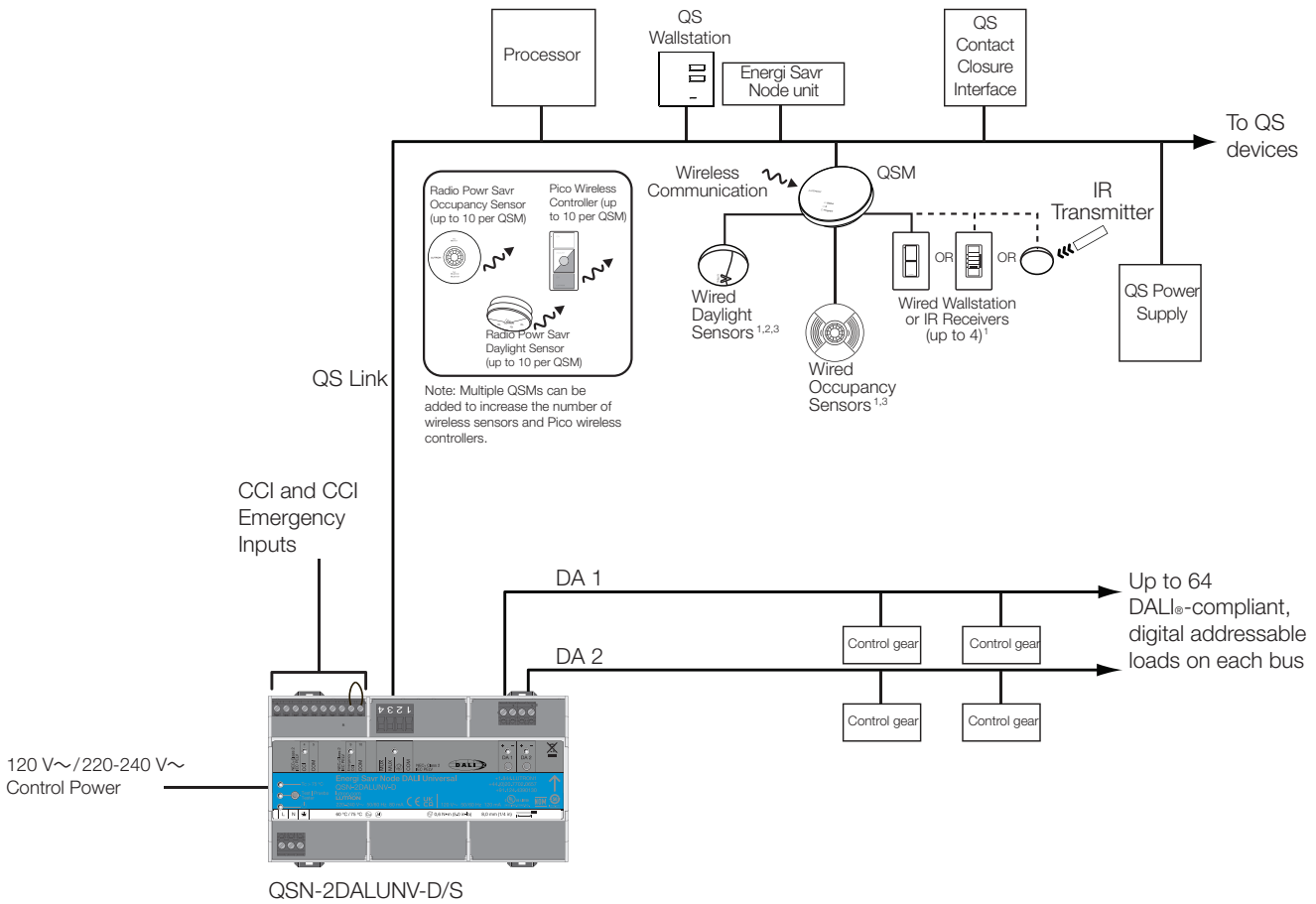

- <sup>1</sup> Up to 4 wired sensors or Pico wireless controllers total (of any type) per QSM.
- <sup>2</sup> The maximum number of daylight sensors (wired and wireless) that an ESN module can support is four (1 per zone).
- <sup>3</sup> Not all products shown are available in all regions.

Job Name:	Model Numbers:
Job Number:	

## Specifications

### Power

- QSN-2DALUNV-D: 120/220-240 V~ 50/60 Hz, max 120 mA
- QSN-2DALUNV-S: 120 V~ 50/60 Hz max 120 mA
- Lightning strike protection meets ANSI/IEEE standard 62.31-1980. Can withstand voltage surges of up to 6000 V~ and current surges of up to 3000 A
- DALI® Bus Output: 16 V= 128 mA guaranteed supply current, 250 mA maximum supply current per bus

### Standards

#### QSN-2DALUNV-D

- Lutron Quality Systems registered to ISO 9001:2015
- IEC 60669-2-5
- DALI-2® certified - IEC 62386-101 and IEC62386-103 ed.2
- NOM Certified
- ICES-3(B)/NMB-3(B)
- FCC Part 15
- cULus Listed

#### QSN-2DALUNV-S

- Lutron Quality Systems registered to ISO 9001:2015
- NOM Certified
- ICES-3(B)/NMB-3(B)
- FCC Part 15
- cULus Listed
- Complies with requirements for use in other spaces used for environmental air (plenums) per NEC® 201 300.22(C)(3)
- Meets the Canadian National Building Code plenum requirements for a concealed space used as a plenum within a floor or roof assembly

### Environment

- Ambient Temperature Operating Range: 0 °C to 40 °C (32 °F to 104 °F)
- Relative humidity: less than 90% non-condensing
- For indoor use only

### Terminals

- Mains wiring: 1.0 mm<sup>2</sup> to 4.0 mm<sup>2</sup> (18 AWG to 12 AWG)
- DALI® Bus Wiring: 0.5 mm<sup>2</sup> to 4.0 mm<sup>2</sup> (20 AWG to 12 AWG)
- QS Link Wiring: 0.5 mm<sup>2</sup> to 2.5 mm<sup>2</sup> (20 AWG to 12 AWG)
- CCI and CCI Emergency Wiring: 0.5 mm<sup>2</sup> to 1.5 mm<sup>2</sup> (20 AWG to 16 AWG)

### Mounting

#### QSN-2DALUNV-D

- Mount module such that the calibration point maximum is 75 °C (167 °F)
- Intended to mount within an IP20 (minimum) rated consumer panel or breaker panel with integrated DIN rail and dead cover
- 9 DIN modules (161.7 mm)
- For more information on mounting and installation in panels with integrated DIN rail see the **DIN Rail Best Practices Application Note** (P/N 048466) at [www.lutron.com](http://www.lutron.com)

#### QSN-2DALUNV-S

- **Note:** Mount the Energi Savr Node unit in a position where it can be easily located and accessed if service or troubleshooting is necessary
- Mount panel such that the module's calibration point maximum is 75 °C (167 °F)
- Remove metal outer panel cover
- Mount vertically to ensure adequate cooling. Use 4 screws in corners of panel to securely mount unit
- For alternate mounting orientations, refer to the **Mounting for QSN-2DALUNV-S** section in this document
- Unit is 6.375 in (161.7 mm) wide x 2.375 in (60.6 mm) tall.

... continued on next page

Job Name:	Model Numbers:
Job Number:	

## Specifications *(continued)*

### DALI® Buses

- Energi Savr Node unit has an integrated bus power supply that provides a guaranteed current of 128 mA (maximum of 250 mA) to power each bus.
- Energi Savr Node unit is a DALI® single master controller and therefore no other controllers or sensors may exist on the same DALI® bus.
- Some DALI® loads may be polarity sensitive; refer to individual manufacturers' specifications for proper connection to the DALI® bus.
- Short circuit protection with automatic re-start (610 ms shutdown delay with a 3 second re-start followed by 800 ms shutdown delay with 160 ms retry time).

## Troubleshooting and Maintenance Features

- Maintains redundant memory of control gear programming for ease of single- and multi-control gear replacement.
- After installation, "TEST" button verifies DALI® wiring on all fixtures.

Job Name:	Model Numbers:
Job Number:	

# Overview of Wiring Terminals and Mechanical Dimensions

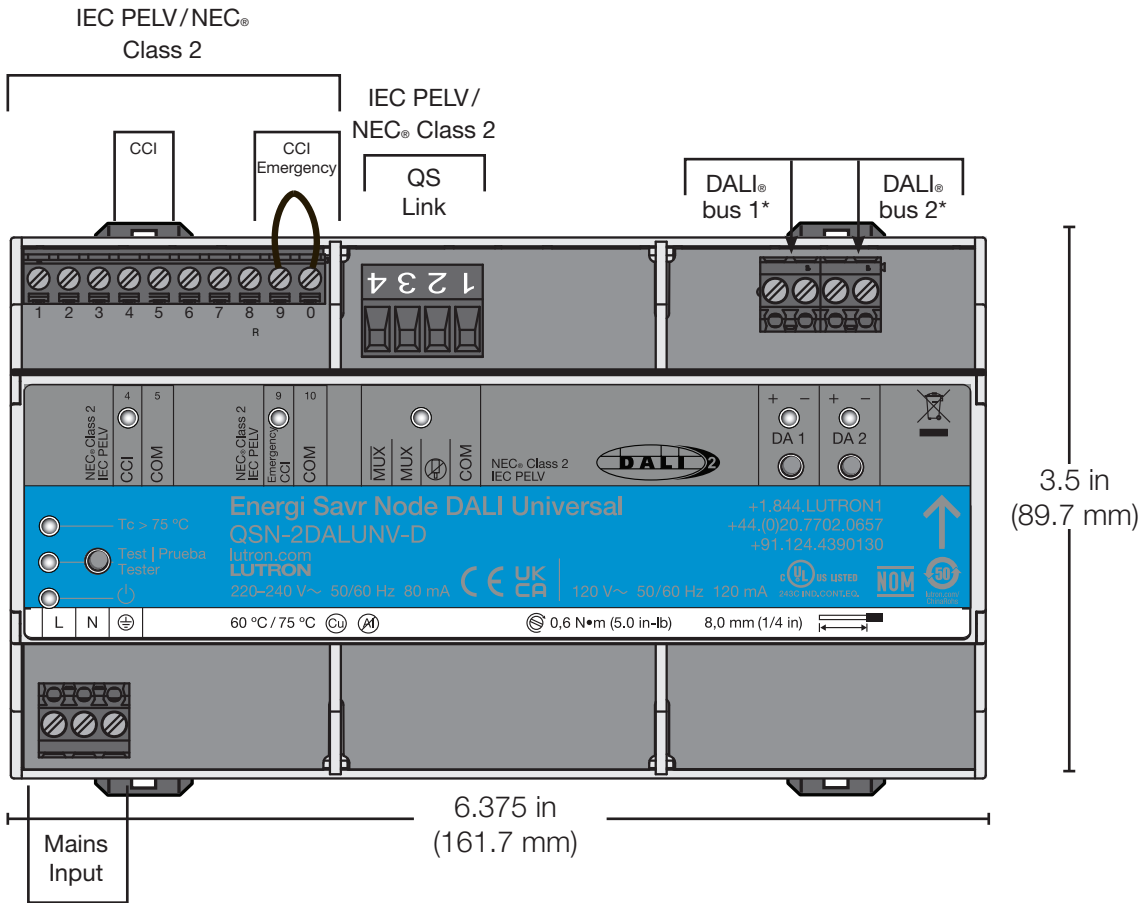

\* Wire DALI® according to local codes

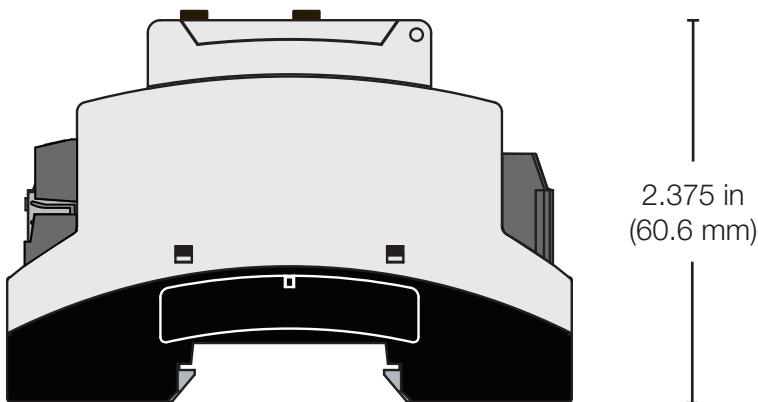

Job Name:	Model Numbers:
Job Number:	

# Mechanical Dimensions

All dimensions shown as mm (in)

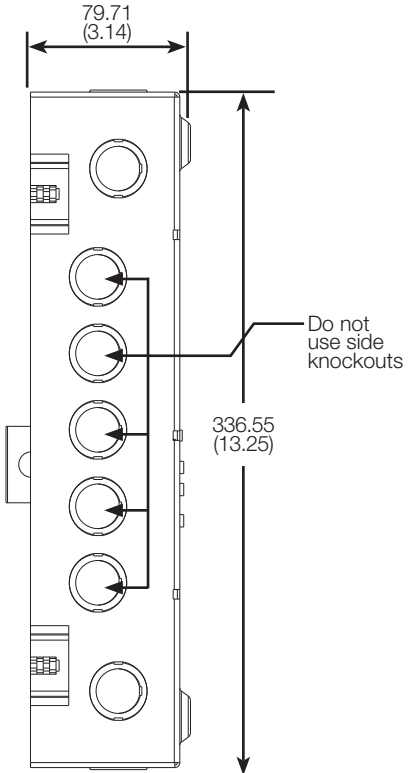
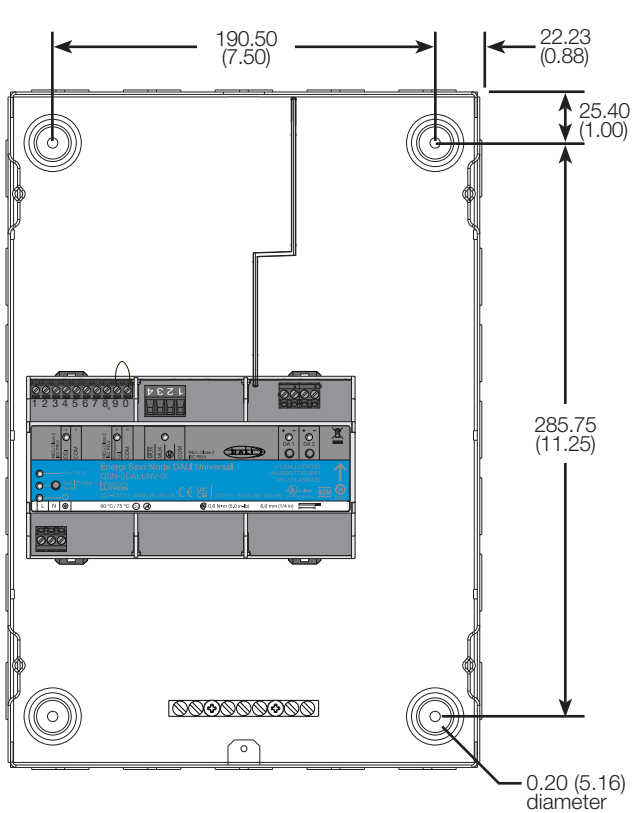
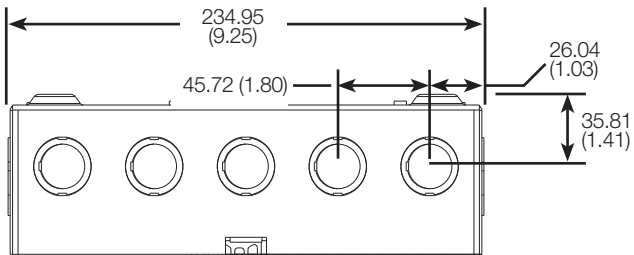

Job Name:	Model Numbers:
Job Number:	

## Mounting for QSN-2DALUNV-S

- For indoor use only
- Surface-mount
- Mount the ESN unit in a position where it can be easily located and accessed if service or troubleshooting is necessary.
- Mount vertically to ensure adequate cooling. Use 4 screws in corners of panel to securely mount the unit.
- Unit generates heat, maximum 24 BTUs/hour.

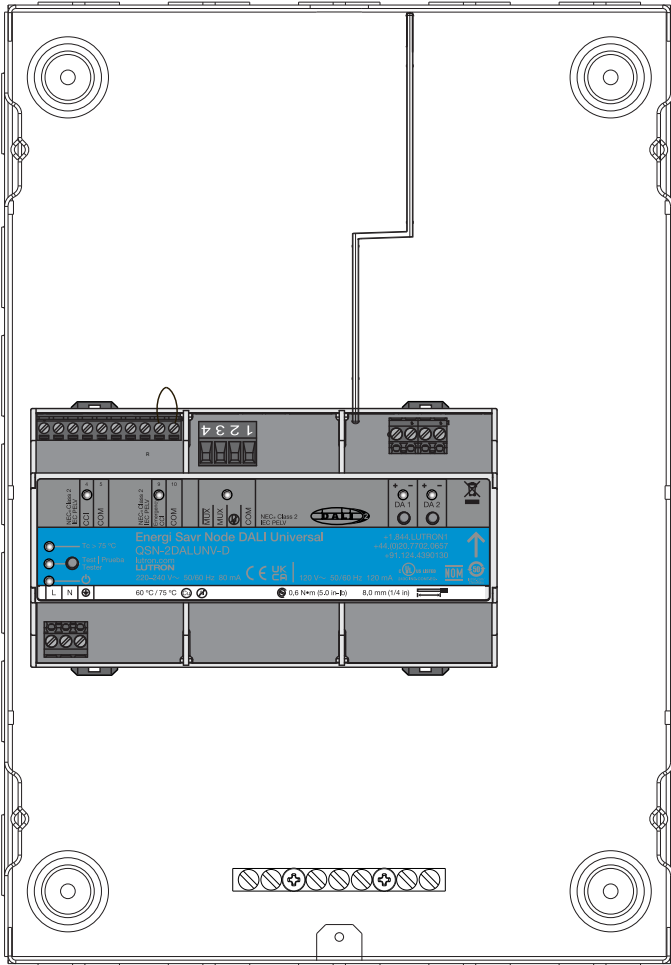

Recommended orientation

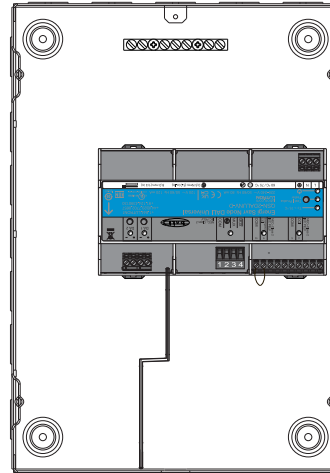

Alternate orientation option

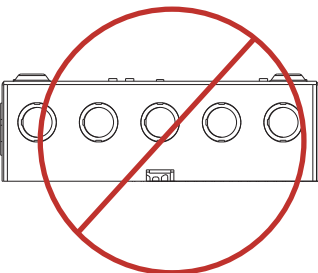
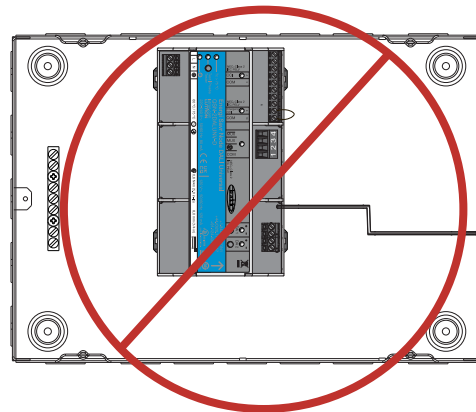
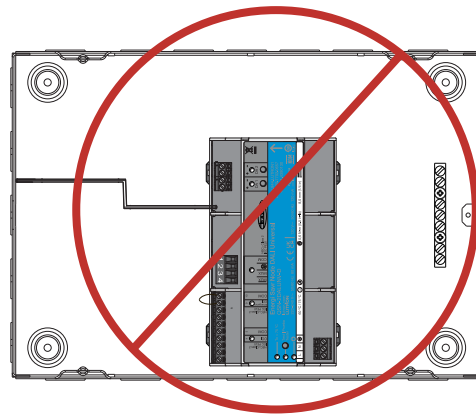

Job Name:	Model Numbers:
Job Number:	

## Wiring: Mains Input

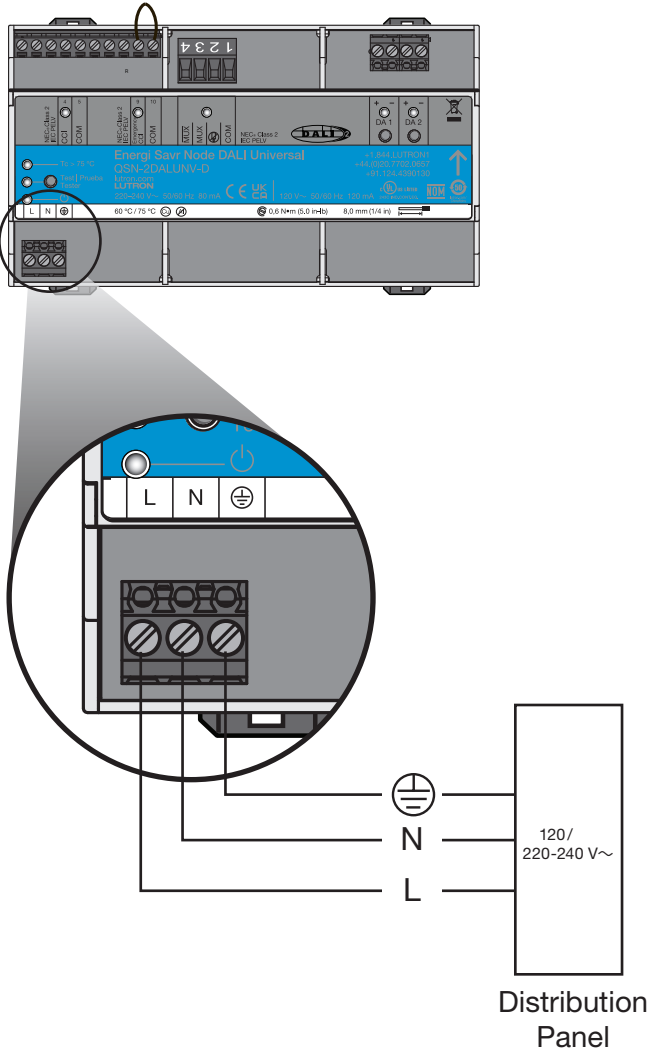

⊕ – Earth/Ground

N – Neutral

L – Mains/Line

### Wiring from Distribution to Bus Supply

- Turn off breaker at distribution panel.
- Run line, neutral, and ⊕ wires from a line/hot feed to the Energi Savr Node unit.

### Emergency Lighting Applications

- Use normal (non-essential) power only.
- When normal power drops out, the Energi Savr Node unit will not power the DALI® buses. When this occurs, control gear powered from emergency feeds go to their system failure level (full light output by default).

### Mains Wiring and Low Voltage Separation

- The Energi Savr Node unit is designed to separate mains wiring from PELV circuits.
- Follow appropriate local and national codes to avoid violating required separation guidelines.

Job Name:	Model Numbers:
Job Number:	



## Wiring: DALI® Bus

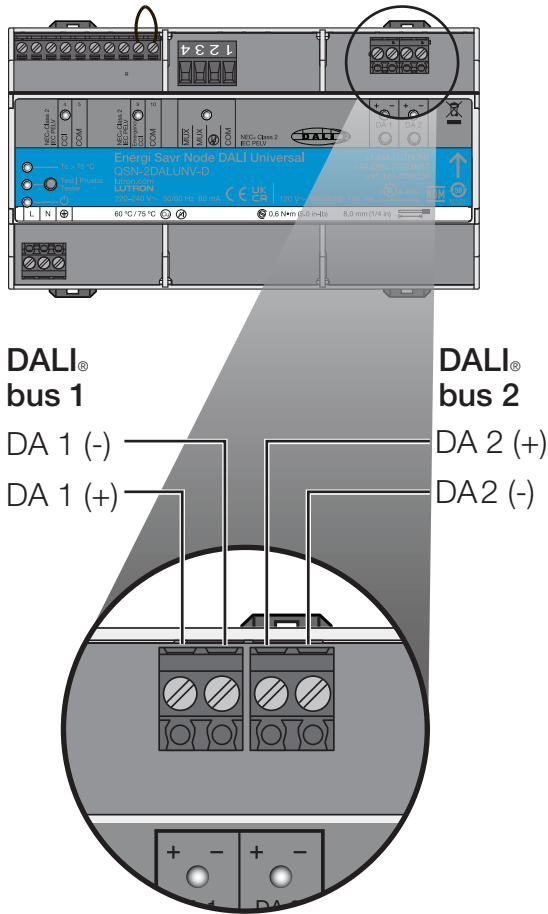

The Energi Savr Node unit will supply power to each DALI® bus independently. Each bus supports a maximum of 64 DALI®-compliant, digital addressable loads per bus.

### DALI® Wiring

- DALI® wiring is not SELV.
- DALI® wiring is treated as mains voltage, and thus may be run within the same sheathing.
- Ensure that there is no greater than a 2 V drop between the Energi Savr Node unit and the end of the DALI® bus.
- Consult all national and local electrical codes for separation requirements.

Wire Gauge	Maximum DALI®-compliant Bus Wire Length *
1.5 mm <sup>2</sup> (16 AWG)	300 m (984 ft)
0.75 mm <sup>2</sup> (20 AWG)	150 m (492 ft)
0.50 mm <sup>2</sup> (22 AWG)	100 m (328 ft)

\* Indicates the total length of DALI® wires.

Job Name:	Model Numbers:
Job Number:	

### Wiring: QS Link

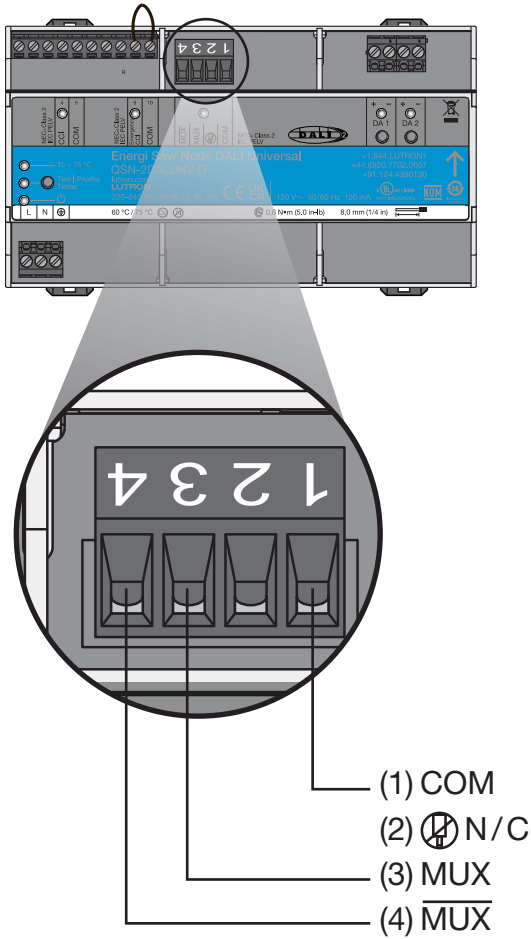

Neither supplies nor consumes PDUs

### QS Link Wiring (IEC PELV/NEC® Class 2)

- Link communicates using IEC PELV wiring.
- Follow all applicable national and local codes for proper circuit separation and protection.
- Wiring may be daisy chained or t-tapped.
- Total length of QS link must not exceed 610 m (2000 ft).

QS Link Wiring Length	Wire Gauge	Available from Lutron in one cable:*
Less than 153 m (502 ft)	Power (terminals 1 and 2): 1 pair 1.0 mm <sup>2</sup> (18 AWG)	QS-CBL-LSZH (Low-Smoke Zero-Halogen)
	Data (terminals 3 and 4): 1 pair 0.5 mm <sup>2</sup> (22 AWG), twisted and screened	GRX-CBL-346S (non-plenum) GRX-PCBL-346S (plenum)
153 m to 610 m (502 ft to 2000 ft)	Power (terminals 1 and 2): 1 pair 4.0 mm <sup>2</sup> (12 AWG)	GRX-CBL-46L (non-plenum)
	Data (terminals 3 and 4): 1 pair 0.5 mm <sup>2</sup> (22 AWG), twisted and screened	GRX-PCBL-46L (plenum)

\* Varies by region, refer to the cable spec.

- Use one, twisted-screened pair of 0.5 mm<sup>2</sup> (20 AWG) for data link (MUX, MUX).

Job Name:	Model Numbers:
Job Number:	

## Wiring: Contact Closure Inputs

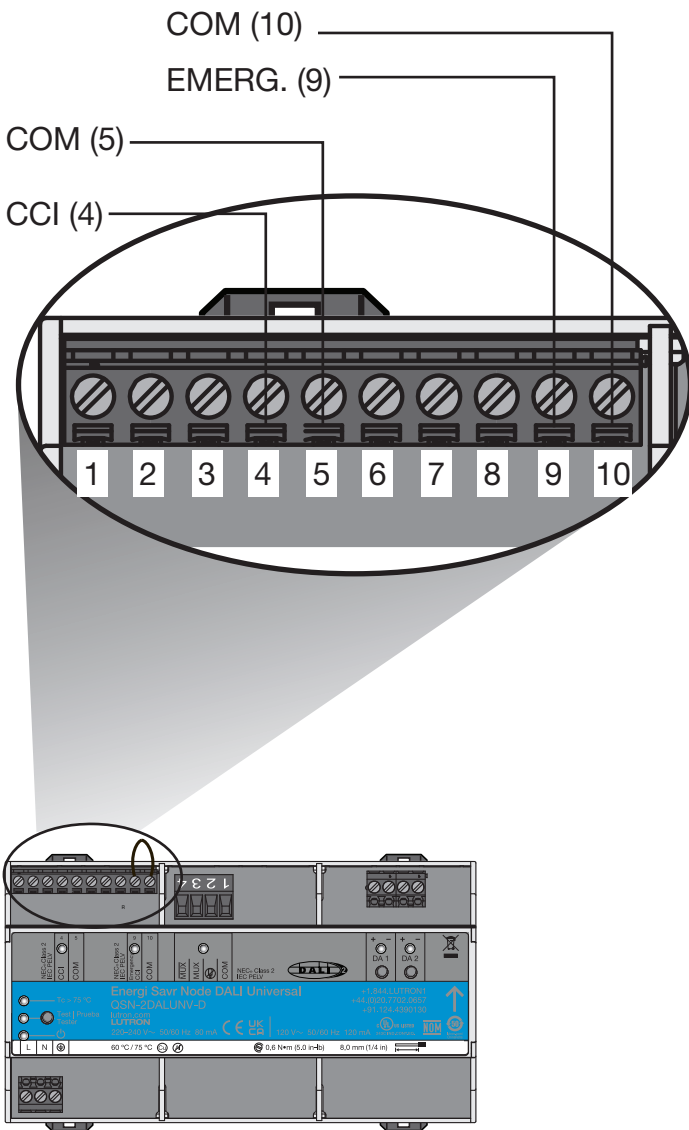

### Emergency CCI Wiring (IEC PELV/NEC® Class 2)

- The attached device must provide a closed dry contact closure or solid-state output.
- Input is miswire-protected up to 36 V<sub>DC</sub>.
- The Energi Savr Node unit with DALI® is shipped with a jumper pre-installed in the Emergency Contact Closure Input.
- Emergency mode is activated by opening the Emergency Contact Closure. Pre-installed jumper must be removed to utilize this function.
- See the **Emergency Lighting Systems Application Note (P/N 048106)** at [www.lutron.com](http://www.lutron.com) for more details.

### CCI Wiring (IEC PELV/NEC® Class 2)

- The attached device must provide a dry contact closure, solid-state output, open collector or active-low (NPN)/active-high (PNP) output.
  - Open collector NPN or active-low on-state voltage must be less than 1 V<sub>DC</sub> and sink 3.0 mA
  - Output collector PNP or active-high on-state voltage must be greater than 12 V<sub>DC</sub> and source 3.0 mA
  - The outputs must stay in the closed or open states for at least 40 msec in order to be recognized by the Energi Savr Node unit
- If there is any question as to whether the third-party device generating these outputs is compatible with these specifications, contact the manufacturer.
- Input is miswire-protected up to 36 V<sub>DC</sub>.

The Lutron logo, Lutron, Athena, Energi Savr Node, GRAFIK Eye, myRoom, Pico, Quantum, Radio Powr Savr, and seeTouch are trademarks or registered trademarks of Lutron Electronics Co., Inc. in the US and/or other countries. All other product names, logos, and brands are property of their respective owners.

## LUTRON SPECIFICATION SUBMITTAL

Page

Job Name:	Model Numbers:
Job Number:	